

MOUNTING FLANGE

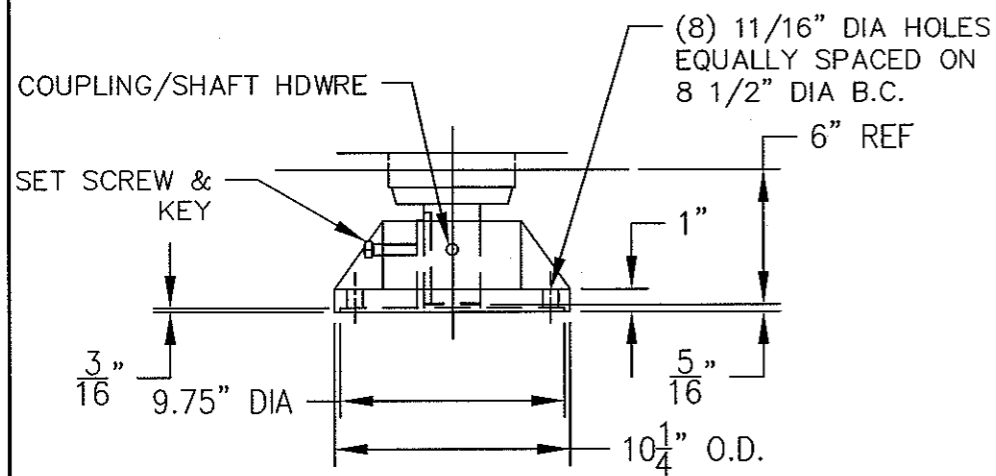

DETAIL OF DRIVE HALF COUPLING

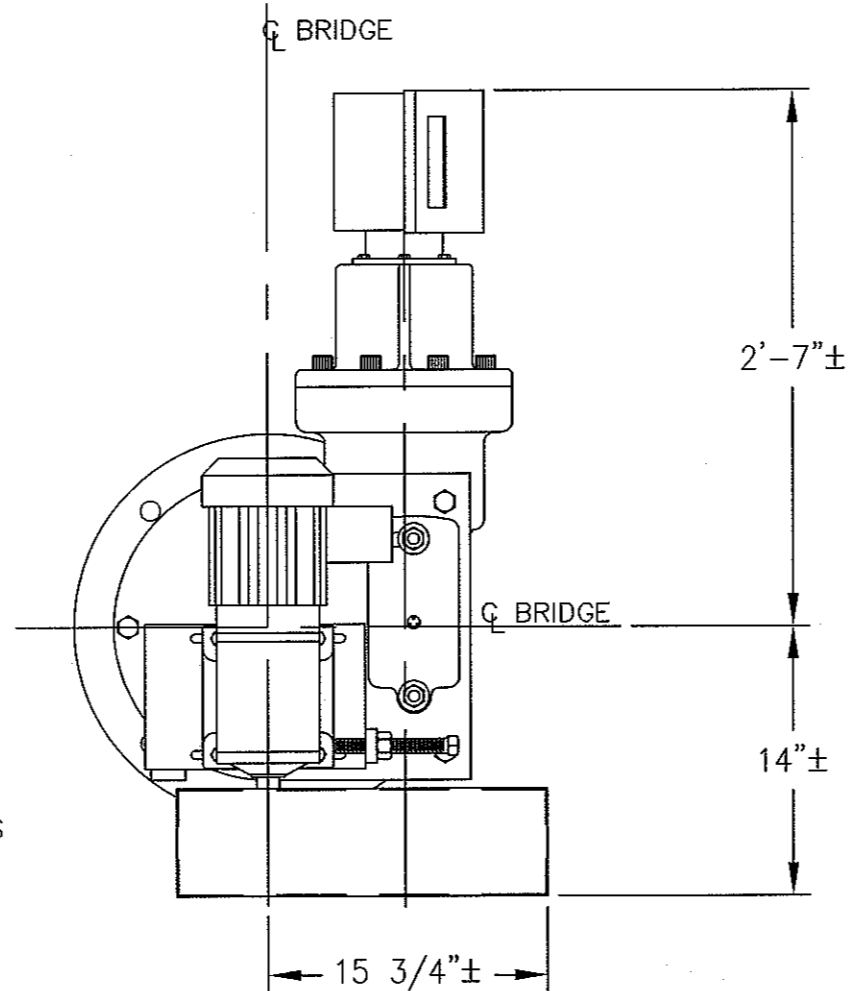

CLOCKWISE ROTATION ONLY

PLAN

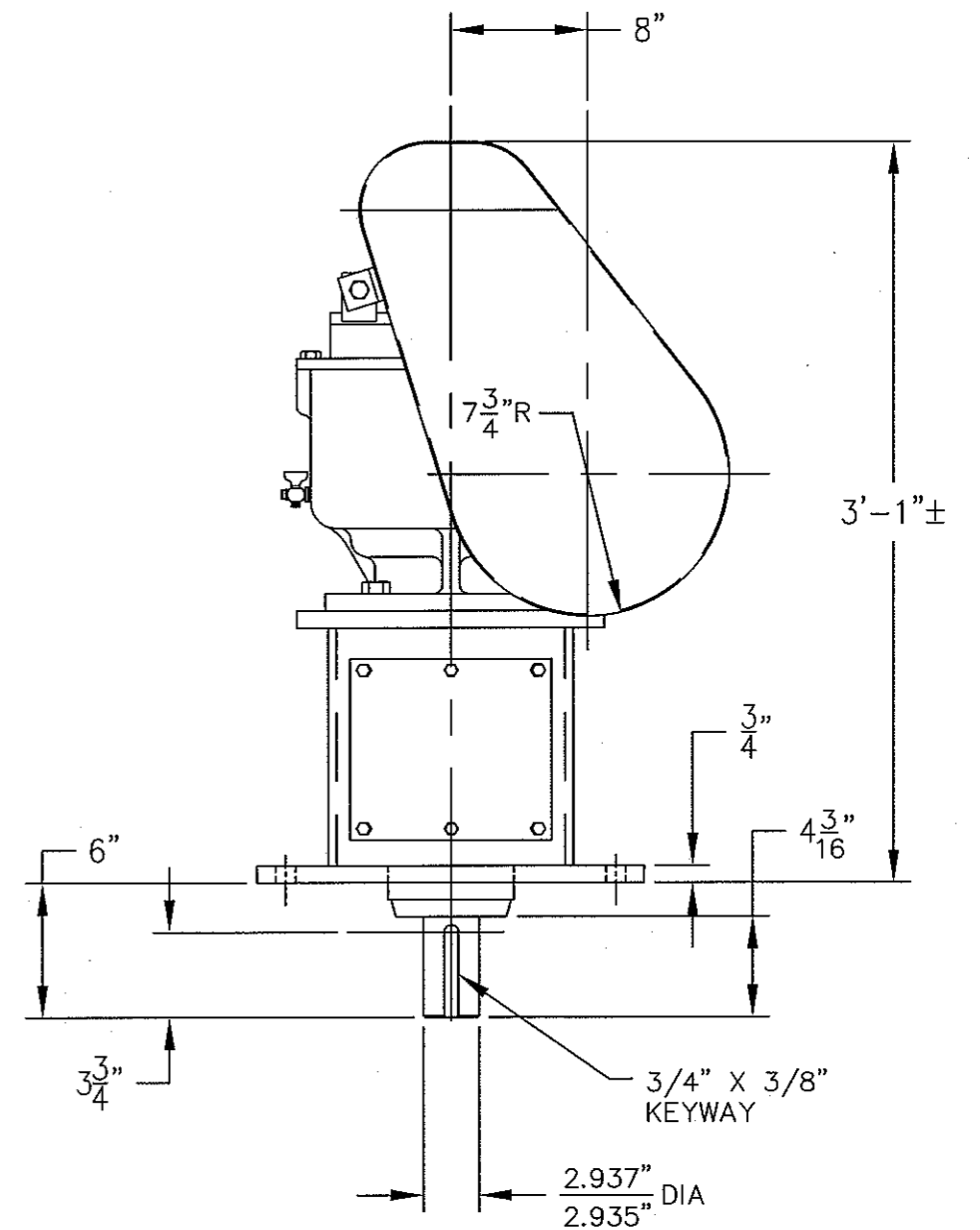

ELEVATION

NOTE: TYPICAL DIMENSIONS, NOT FOR CONSTRUCTION

WEIGHT: 1050 LBS APPROX.

CAD FILE: B73898

MASTER
B-54783

SYM	REVISION	BY	DATE	CHKD
4				
3				
2				
1				

	DATE	BY
DRAWN	02/06/13	R. WALT
CHECKED		
APP'D.		
SCALE		

This is the property of McNish Corporation and is to be used only in connection with the performance of work by McNish Corporation. Reproduction in whole or in part for any other purpose is expressly forbidden.

McNISH
CORPORATION
AURORA, ILLINOIS, USA

McNish Circular Clarifier Drives		
GENERAL ARRANGEMENT MODELS 8B1, 8B2, 8B3 & 8B4 DRIVES		
CONTRACT	DRAWING NO.	REV.
B,2,0,5	7,3,8,9,8	1,6,7,0